



# Indoor LED Soft Module

Quick Start Guide

# Legal Information

## About this Document

- This Document includes instructions for using and managing the Product. Pictures, charts, images and all other information hereinafter are for description and explanation only.
- The information contained in the Document is subject to change, without notice, due to firmware updates or other reasons. Please find the latest version of the Document at the Hikvision website (<https://www.hikvision.com>). Unless otherwise agreed, Hangzhou Hikvision Digital Technology Co., Ltd. or its affiliates (hereinafter referred to as "Hikvision") makes no warranties, express or implied.
- Please use the Document with the guidance and assistance of professionals trained in supporting the Product.

## About this Product

This product can only enjoy the after-sales service support in the country or region where the purchase is made.

## Acknowledgment of Intellectual Property Rights

- Hikvision owns the copyrights and/or patents related to the technology embodied in the Products described in this Document, which may include licenses obtained from third parties.
- Any part of the Document, including text, pictures, graphics, etc., belongs to Hikvision. No part of this Document may be excerpted, copied, translated, or modified in whole or in part by any means without written permission.
- **HIKVISION** and other Hikvision's trademarks and logos are the properties of Hikvision in various jurisdictions.
- Other trademarks and logos mentioned are the properties of their respective owners.
- **HDMI**<sup>™</sup> The terms HDMI and HDMI High-Definition Multimedia Interface, and the HDMI Logo are trademarks or registered trademarks of HDMI Licensing Administrator, Inc. in the United States and other countries.

## LEGAL DISCLAIMER

- TO THE MAXIMUM EXTENT PERMITTED BY APPLICABLE LAW, THIS DOCUMENT AND THE PRODUCT DESCRIBED, WITH ITS HARDWARE, SOFTWARE AND FIRMWARE, ARE PROVIDED "AS IS" AND "WITH ALL FAULTS AND ERRORS". HIKVISION MAKES NO WARRANTIES, EXPRESS OR IMPLIED, INCLUDING WITHOUT LIMITATION, MERCHANTABILITY, SATISFACTORY QUALITY, OR FITNESS FOR A PARTICULAR PURPOSE. THE USE OF THE PRODUCT BY YOU IS AT YOUR OWN RISK. IN NO EVENT WILL HIKVISION BE LIABLE TO YOU FOR ANY SPECIAL, CONSEQUENTIAL, INCIDENTAL, OR INDIRECT DAMAGES, INCLUDING, AMONG OTHERS, DAMAGES FOR LOSS OF

BUSINESS PROFITS, BUSINESS INTERRUPTION, OR LOSS OF DATA, CORRUPTION OF SYSTEMS, OR LOSS OF DOCUMENTATION, WHETHER BASED ON BREACH OF CONTRACT, TORT (INCLUDING NEGLIGENCE), PRODUCT LIABILITY, OR OTHERWISE, IN CONNECTION WITH THE USE OF THE PRODUCT, EVEN IF HIKVISION HAS BEEN ADVISED OF THE POSSIBILITY OF SUCH DAMAGES OR LOSS.

- YOU ACKNOWLEDGE THAT THE NATURE OF THE INTERNET PROVIDES FOR INHERENT SECURITY RISKS, AND HIKVISION SHALL NOT TAKE ANY RESPONSIBILITIES FOR ABNORMAL OPERATION, PRIVACY LEAKAGE OR OTHER DAMAGES RESULTING FROM CYBER-ATTACK, HACKER ATTACK, VIRUS INFECTION, OR OTHER INTERNET SECURITY RISKS; HOWEVER, HIKVISION WILL PROVIDE TIMELY TECHNICAL SUPPORT IF REQUIRED.
- YOU AGREE TO USE THIS PRODUCT IN COMPLIANCE WITH ALL APPLICABLE LAWS, AND YOU ARE SOLELY RESPONSIBLE FOR ENSURING THAT YOUR USE CONFORMS TO THE APPLICABLE LAW. ESPECIALLY, YOU ARE RESPONSIBLE, FOR USING THIS PRODUCT IN A MANNER THAT DOES NOT INFRINGE ON THE RIGHTS OF THIRD PARTIES, INCLUDING WITHOUT LIMITATION, RIGHTS OF PUBLICITY, INTELLECTUAL PROPERTY RIGHTS, OR DATA PROTECTION AND OTHER PRIVACY RIGHTS. YOU SHALL NOT USE THIS PRODUCT FOR ANY PROHIBITED END-USES, INCLUDING THE DEVELOPMENT OR PRODUCTION OF WEAPONS OF MASS DESTRUCTION, THE DEVELOPMENT OR PRODUCTION OF CHEMICAL OR BIOLOGICAL WEAPONS, ANY ACTIVITIES IN THE CONTEXT RELATED TO ANY NUCLEAR EXPLOSIVE OR UNSAFE NUCLEAR FUEL-CYCLE, OR IN SUPPORT OF HUMAN RIGHTS ABUSES.
- IN THE EVENT OF ANY CONFLICTS BETWEEN THIS DOCUMENT AND THE APPLICABLE LAW, THE LATTER PREVAILS.

**© Hangzhou Hikvision Digital Technology Co., Ltd. All rights reserved.**



## Applicable Models

This manual is applicable to indoor full-color LED soft modules.

Series	Model	Product
DS-D41QXXCA-1GS	DS-D41Q12CA-1GS	Indoor Full-color LED Soft Module
	DS-D41Q15CA-1GS	
	DS-D41Q18CA-1GS	
	DS-D41Q20CA-1GS	
	DS-D41Q25CA-1GS	

## Symbol Conventions

The symbols that may be found in this document are defined as follows.

Symbol	Description
 <b>Note</b>	Provides additional information to emphasize or supplement important points of the main text.
 <b>Caution</b>	Indicates a potentially hazardous situation, which if not avoided, could result in equipment damage, data loss, performance degradation, or unexpected results.
 <b>Danger</b>	Indicates a hazard with a high level of risk, which if not avoided, will result in death or serious injury.

## Safety Instructions

### **Danger**

- To reduce the risk of fire or electric shock, please do not expose the device to rain or humid environment.
- Do not connect several devices to one power adapter as adapter overload may cause overheating or a fire hazard.
- Electric discharge may last for a short period of time after the power is shut down. Please wait two minutes after the power is shut down before operating the device.
- To avoid the risk of electric shock, please do not operate when the power is on.
- Please do not plug and unplug the power cable when the power is on.

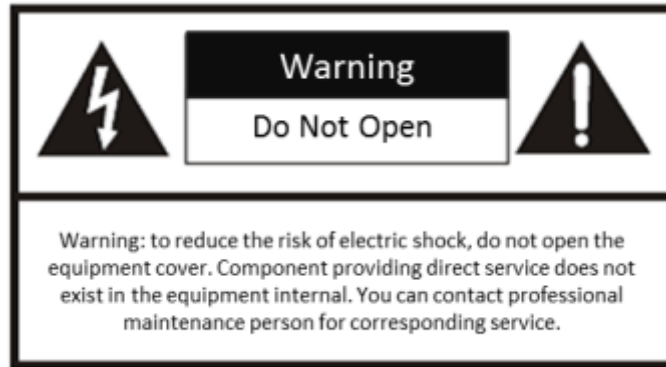

 **Caution**

- This product may cause electrical interference in indoor environments, for which the user may need to take appropriate measures.

# TABLE OF CONTENTS

<b>Chapter 1 Product Introduction .....</b>	<b>1</b>
1.1 Overview .....	1
1.2 Appearance .....	1
1.3 Bend the Module .....	2
<b>Chapter 2 Installation .....</b>	<b>4</b>
2.1 Precautions .....	4
2.2 Install the Module .....	4
2.2.1 Cylindrical Screen Installation .....	5
2.2.2 Curved Screen Installation .....	9
2.3 Connect Power Cables .....	13
2.3.1 P1.2 Module .....	14
2.3.2 P1.5 Module .....	14
2.4 Connect Signal Cables .....	15
2.4.1 P1.2 Module .....	15
2.4.2 P1.5 Module .....	16
<b>Chapter 3 Configuration .....</b>	<b>17</b>
3.1 Stitch P1.2 Module LED Display .....	17
3.2 Stitch P1.5 Module LED Display .....	20

# Chapter 1 Product Introduction

## 1.1 Overview

The full-color LED module (hereinafter referred to as the "module") is the smallest display unit of the full-color display, which is composed of LED pixels or modules welded on the driver board with the function of display images and structural installation.

The center distance between two pixels is called pixel pitch. The smaller pixel pitch results in higher pixel density per unit area, higher resolution and higher cost. For example, P3 indicates 3 mm pixel pitch.

## 1.2 Appearance

The appearance of module is shown as follows.

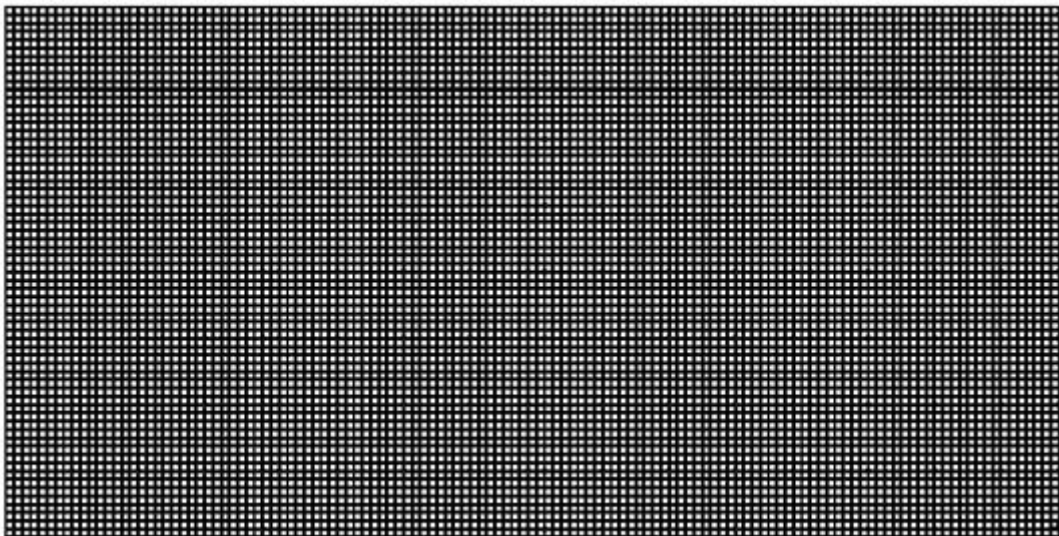

Front

Figure 1-1 Front Panel

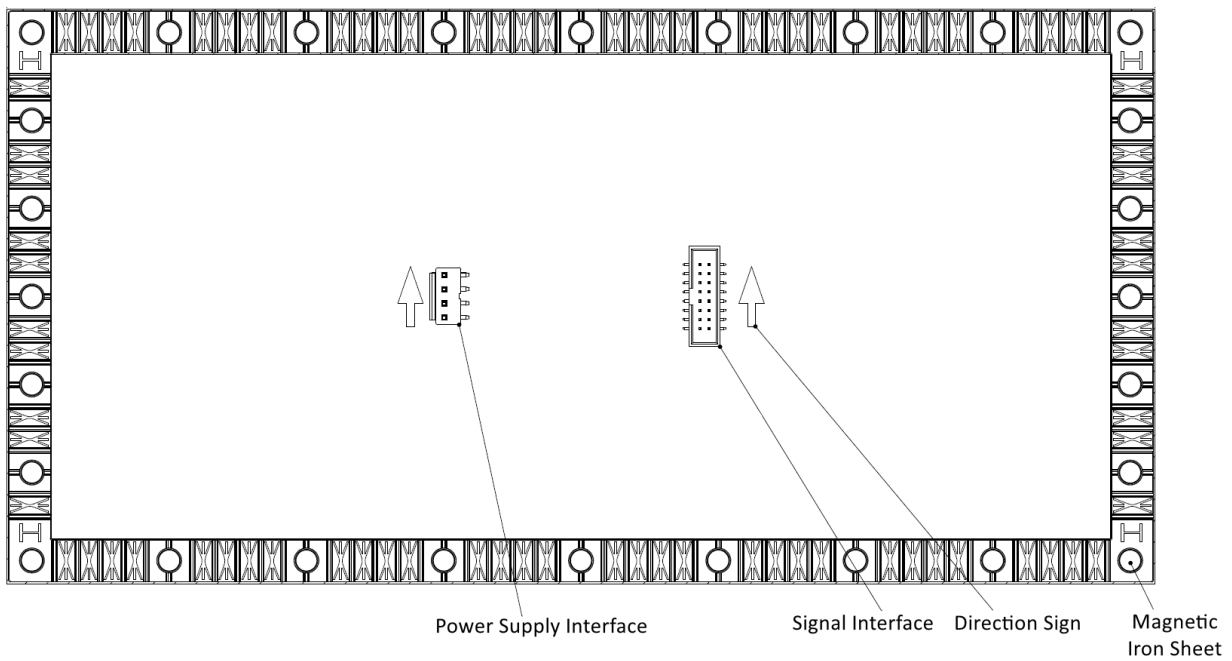

Figure 1-2 Rear Panel

### 1.3 Bend the Module

The longer side of the module can be bent. After bending, the recommended minimum chord length will be 311.8 mm and the recommended bending angle is 157°. It is suggested that the actual installed length is greater than 311.8 mm.

 **Note**

The short side of the module can not be bent.

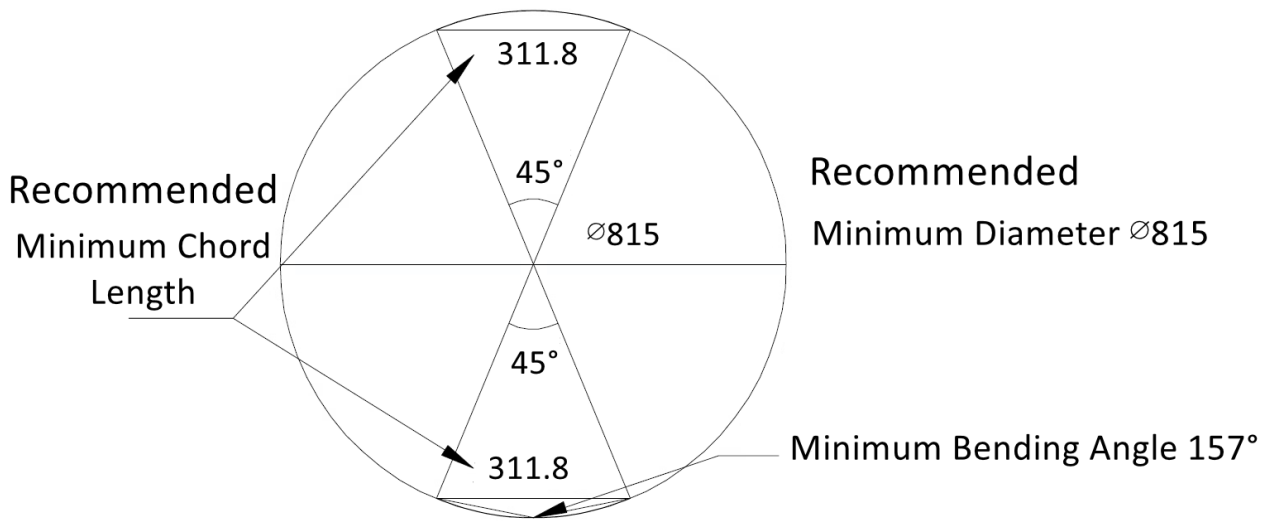

Figure 1-3 Bending Requirement

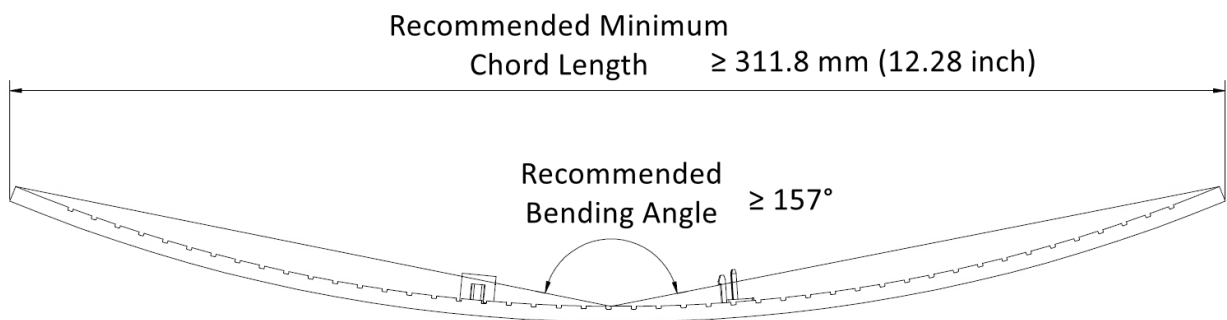

Figure 1-4 Bent Module Diagram

## Chapter 2 Installation

### 2.1 Precautions

Read the following precaution tips before you install the device.

- Electric discharge may last for a short period of time after the power is shut down. Please wait two minutes after the power is shut down to operate the device.
- Only use the original power cord delivered with the device. Contact authorized dealer to purchase power cord with same specifications.
- Please do not frequently plug and unplug the power cord when the power is on.
- To reduce the risk of fire or electric shock, please do not expose the device to rain or humid environment.
- Please make sure that the decoration is basically completed before screen installation, to avoid moisture and high acidic and alkaline environment to damage the lamp beads.

### 2.2 Install the Module

#### Installation Precautions

- Installation personnel shall wear protective equipment, wear safety helmets and safety belts when working at heights.
- When installing the module, the installation personnel must wear anti-static gloves to avoid sweat stains and fingerprints left on the screen.
- Galvanized square tubes are not allowed to be used for installation, because the flatness of galvanized square tubes cannot be guaranteed.
- It is recommended to use the simple arc and cylindrical sheet metal iron box with spraying process, which is easy to install and has good flatness.
- Please check that all the structural parts and fasteners are installed completely without missing.
- After the installation is completed, the support frame shall be kept vertical to the horizontal plane, no forward or lateral inclination, distortion, etc., and no obvious misalignment.
- After the accessories are installed, all the debris in the frame shall be cleaned, and no metal debris shall be left.
- The overall horizontal error of the rack frame is no more than 1 mm, and the vertical error is no more than 1 mm.

- The flatness error of the module is no more than 0.1 mm, the horizontal error of the whole screen is no more than 1 mm, the vertical error is no more than 1 mm, and there is no obvious misalignment between lamp beads on the adjacent modules.
- After each module is installed, it is necessary to check the short difference between neighboring modules. If there is a significant short difference (generally greater than 0.1 mm), it is necessary to adjust the height by using the crepe paper for masking tape on the shorter side of the bracket until the module is well adjusted.

 **Note**

- When installing the module, you need to install them according to the load capability of receiving card.
- When wiring modules, you must start wiring down from the first module in the upper left corner (viewed from the front).

## 2.2.1 Cylindrical Screen Installation

### ***Before You Start***

Confirm the final position of the screen installation.

---

 **Caution**

Please determine the installation position according to the serial number of the cabinet and the project drawings.

---

### **Steps**

Step 1 Align the longer side of the rack frame to the wall and keep the frame vertical to the ground.

Step 2 Insert the expansion bolts to fix rack frame onto the wall.

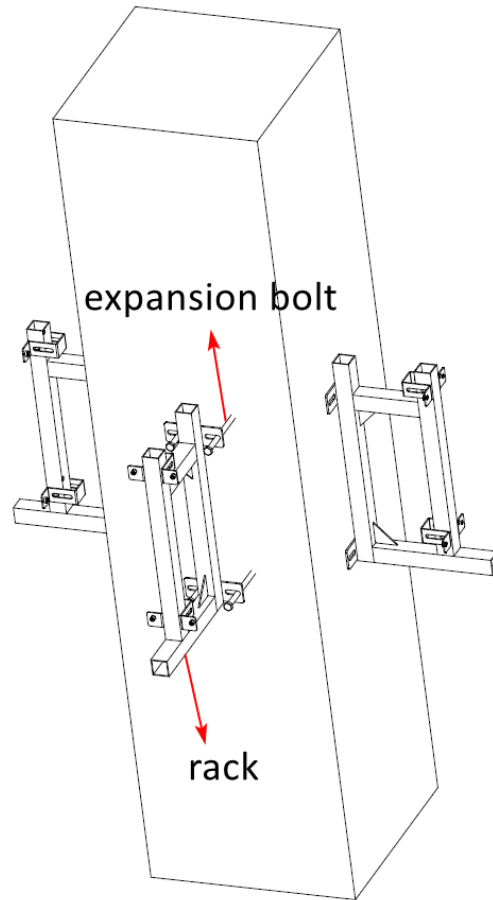

Figure 2-1 Fix the Rack

Step 3 Use a zigzag connector to fix the cabinet frame with rack frame and insert the screws to secure the frames.

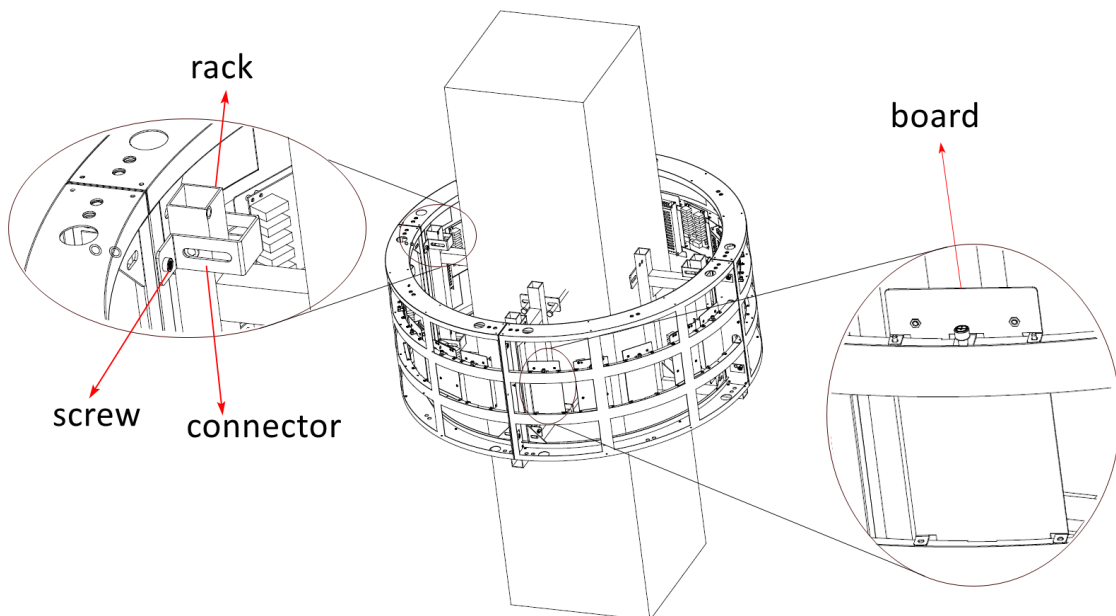

Figure 2-2 Connect the Frames

 **Note**

Do not fix the screws too tight for future adjustments.

Step 4 Stitch the remaining cabinet frames one by one.

Step 5 Connect the power cords to the interfaces of the power supply in cascade, and insert signal cables into the receiving card slot in cascade. Fix the power supply or the receiving card on the board with M3 screws and then install them on the middle of the cabinet frame.

Step 6 Put the module on the front of the cabinet frame, and align the module and the upper edge of cabinet frame initially. Align the left, top, or bottom edge of the module to the left, top, or bottom edge of the cabinet frame. And then align and absorb the remaining three sides of the module to the cabinet frame and finish the stitching of remaining modules in the top row of the cabinet frame.

 **Note**

- Please pay attention to the direction sign on the back of module when absorbing the module to the cabinet frame.
- The installation personnel must wear anti-static gloves.
- When fine-tuning the position, it is forbidden to beat the module with violent force.
- The bending angle of the module is between  $157.5^\circ$  and  $180^\circ$ . It is forbidden to tear the module at a large angle and bend the module repeatedly, otherwise it will cause damage to the lamp beads and chips.

Step 7 Stitch a circle of modules at the top and bottom of the cabinet frame.

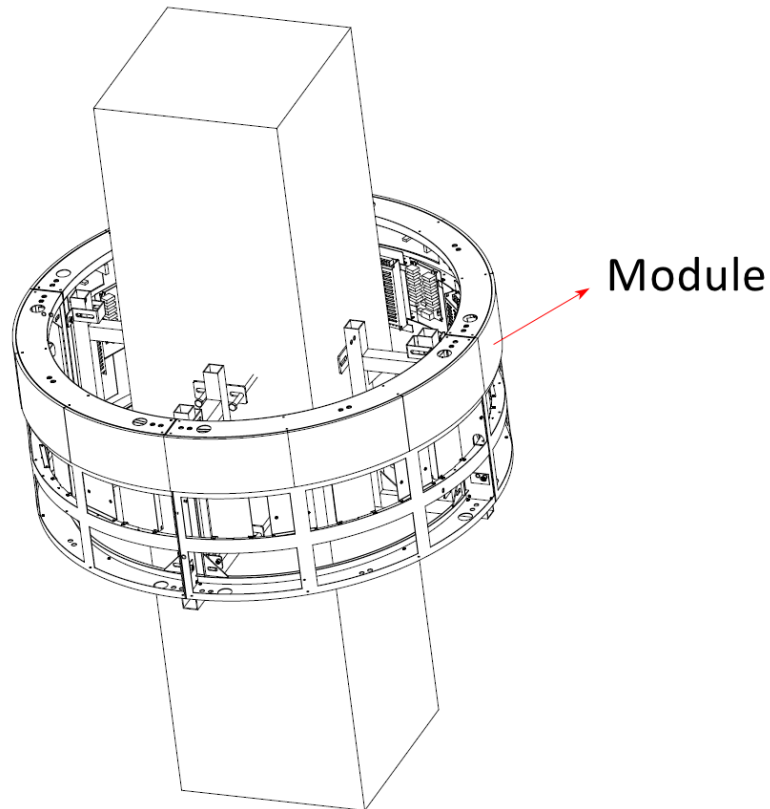

Figure 2-3 Install the Module

Step 8 Adjust the cabinet frame and rack frame by adjust the stitching seam between the modules to confirm the final position of the cabinet frame, and fasten the screws to fix the cabinet and rack frame.

Step 9 Absorb the remaining module to the cabinet frame in order from bottom to top. In the process of the installation, connect the power cables and signal cables with the interfaces on the rear panel of the module.

 **Note**

Violent tearing and pulling are prohibited. When plugging and unplugging the cables, please use both hands to pull out and plug in gently. It is necessary to connect the connector first and then install the module, so as to avoid breaking the copper column and damaging the PCB due to excessive force.

Step 10 A cylindrical LED screen installation is completed.

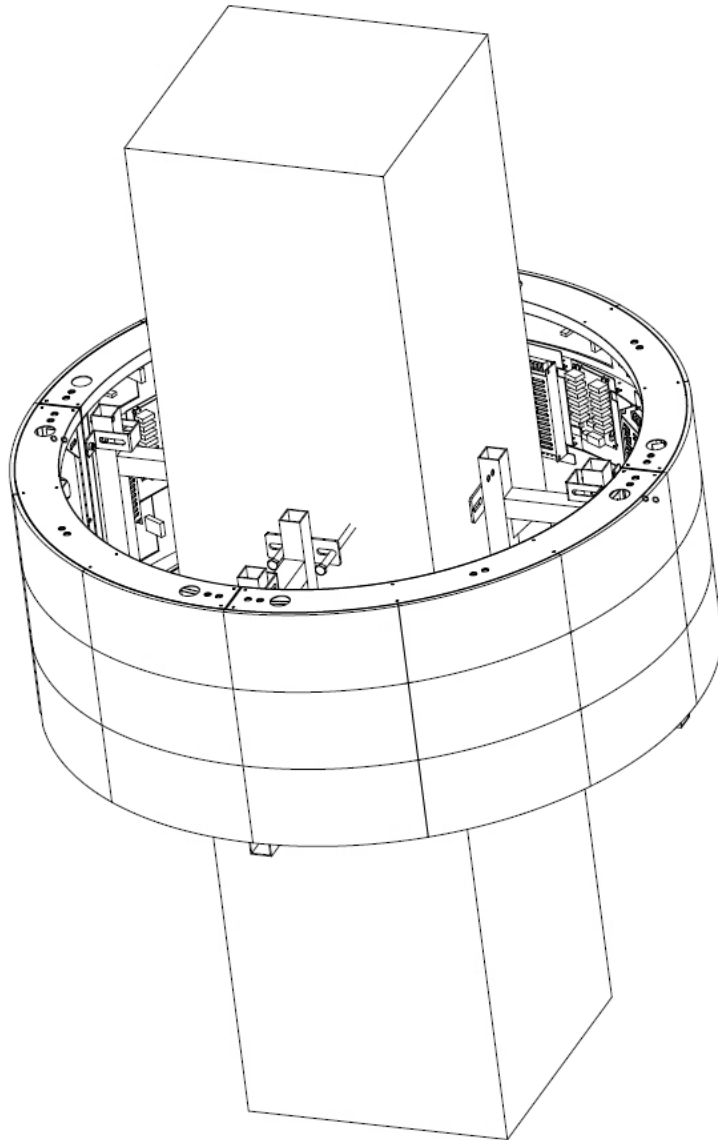

Figure 2-4 Stitch LED Display Unit

 **Note**

The standard thickness of the sheet metal cabinet with modules is 85 mm. The partial thickness is no more than 65 mm, containing rack, connector and screws, and the overall thickness is no more than 150 mm. The cylindrical screen project needs to calculate the size of a circle of modules according to the actual dimensions and round up to the final diameter of the LED screen.

## 2.2.2 Curved Screen Installation

### ***Before You Start***

Confirm the final position of the screen installation.

 **Caution**

Please determine the installation position according to the serial number of the cabinet and the project drawings.

---

**Steps**

Step 1 Use 40 × 3 mm square tubes to make several mounting poles to fix cabinet according to according to the real situation.

Step 2 Place a mounting pole at the joint of two adjacent cabinet frames, and place a joint piece behind the pole. Align the mounting holes on both ends of the joint piece with the mounting holes on the cabinet frame, and insert the fixing bolts to fix the joint piece, the mounting pole, and the cabinet frame, and do not fasten the bolts.

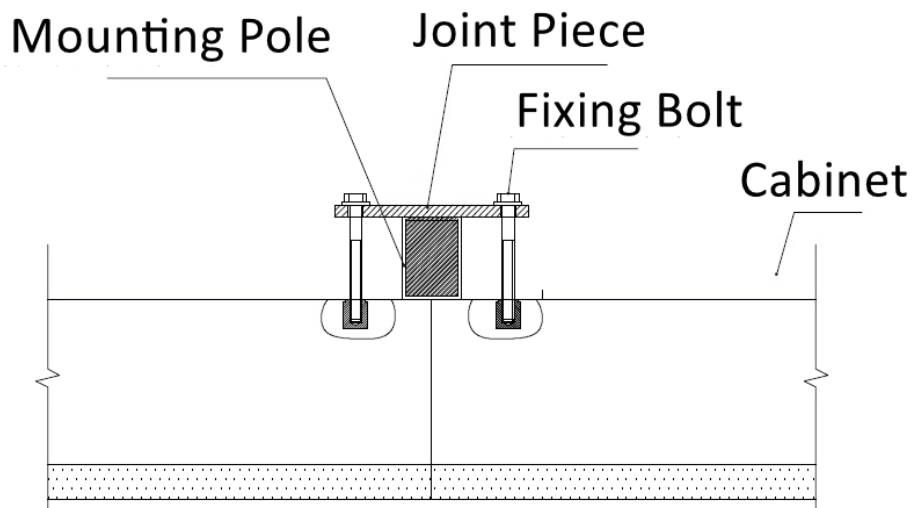

Figure 2-5 Fix the Adjacent Cabinet

Step 3 Stitch the remaining cabinet frames one by one.

Step 4 During the stitching of the cabinet frame, make tie rods to the columns or rear wall, and use expansion bolts to fix them according to the actual conditions.

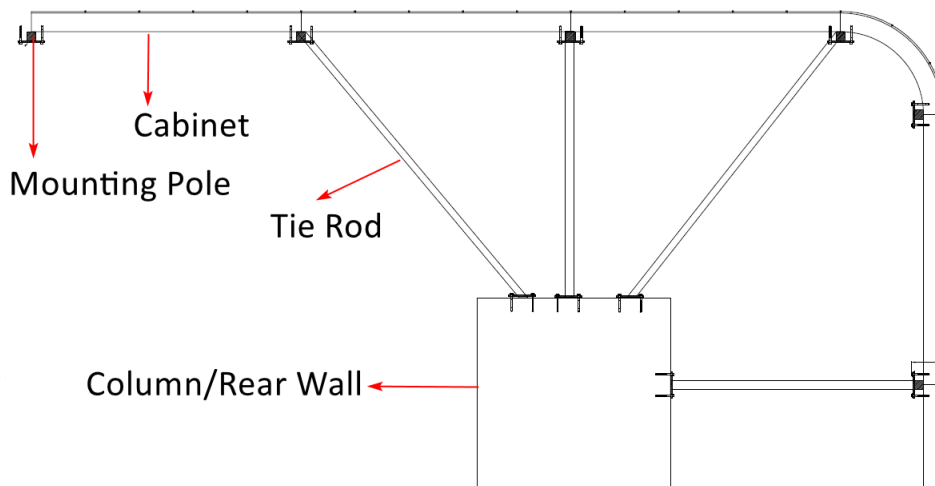

Figure 2-6 Install the Cabinet (Top View)

Step 5 Connect the power cords to the interfaces of the power supply in cascade, and insert signal cables into the receiving card slot in cascade. Fix the power supply or the receiving card on the board with M3 screws and then install them on the middle of the cabinet frame.

Step 6 Put the module on the front of the cabinet frame, and align the module and the upper edge of cabinet frame initially. Align the left, top, or bottom edge of the module to the left, top, or bottom edge of the cabinet frame. And then align and absorb the remaining three sides of the module to the cabinet frame and finish the stitching of remaining modules in the top row of the cabinet frame.

### Caution

- Please pay attention to the direction sign on the back of module when absorbing the module to the cabinet frame.
- The installation personnel must wear anti-static gloves.
- When fine-tuning the position, it is forbidden to beat the module with force.
- The bending angle of the module is between  $157.5^\circ$  and  $180^\circ$ . It is forbidden to tear the module at a large angle and bend the module repeatedly, otherwise it will cause damage to the lamp beads and chips.

Step 7 Stitch a row of modules at bottom of the cabinet frame.

Step 8 Adjust the cabinet frame and rack frame by adjust the stitching seam between the modules to confirm the final position of the cabinet frame, and fasten the screws to fix the cabinet, tie rods and mounting poles.

Step 9 Absorb the remaining module to the cabinet frame in order from bottom to top. In the process of the installation, connect the power cables and signal cables with the interfaces on the rear panel of the module.

**Caution**

Violent tearing and pulling are prohibited. When plugging and unplugging the cables, please use both hands to pull out and plug in gently. It is necessary to connect the connector first and then install the module, so as to avoid breaking the copper column and damaging the PCB due to excessive force.

Step 10 A curved LED screen installation is completed.

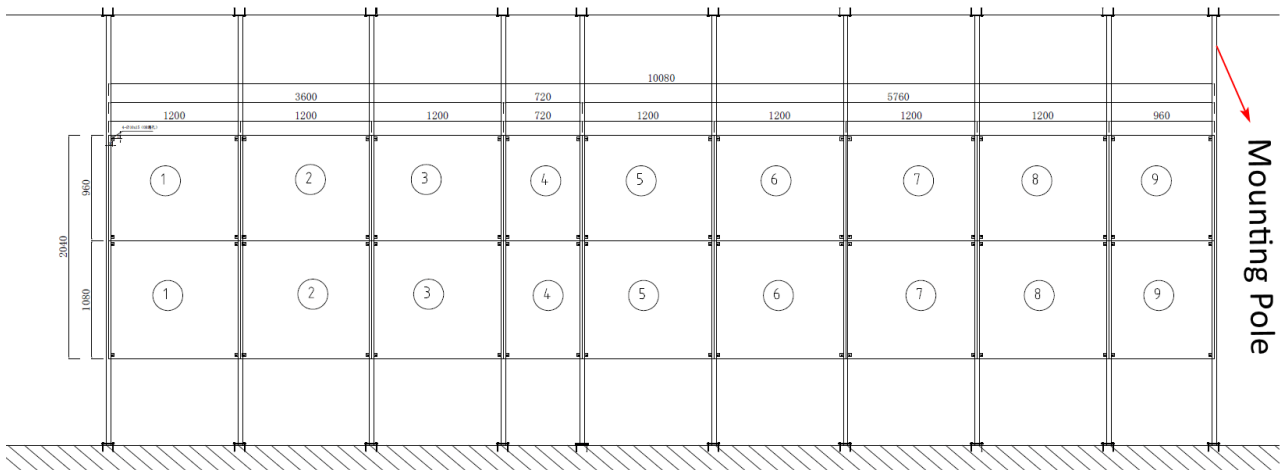

Figure 2-7 Finish the Screen Installation (Front Installation)

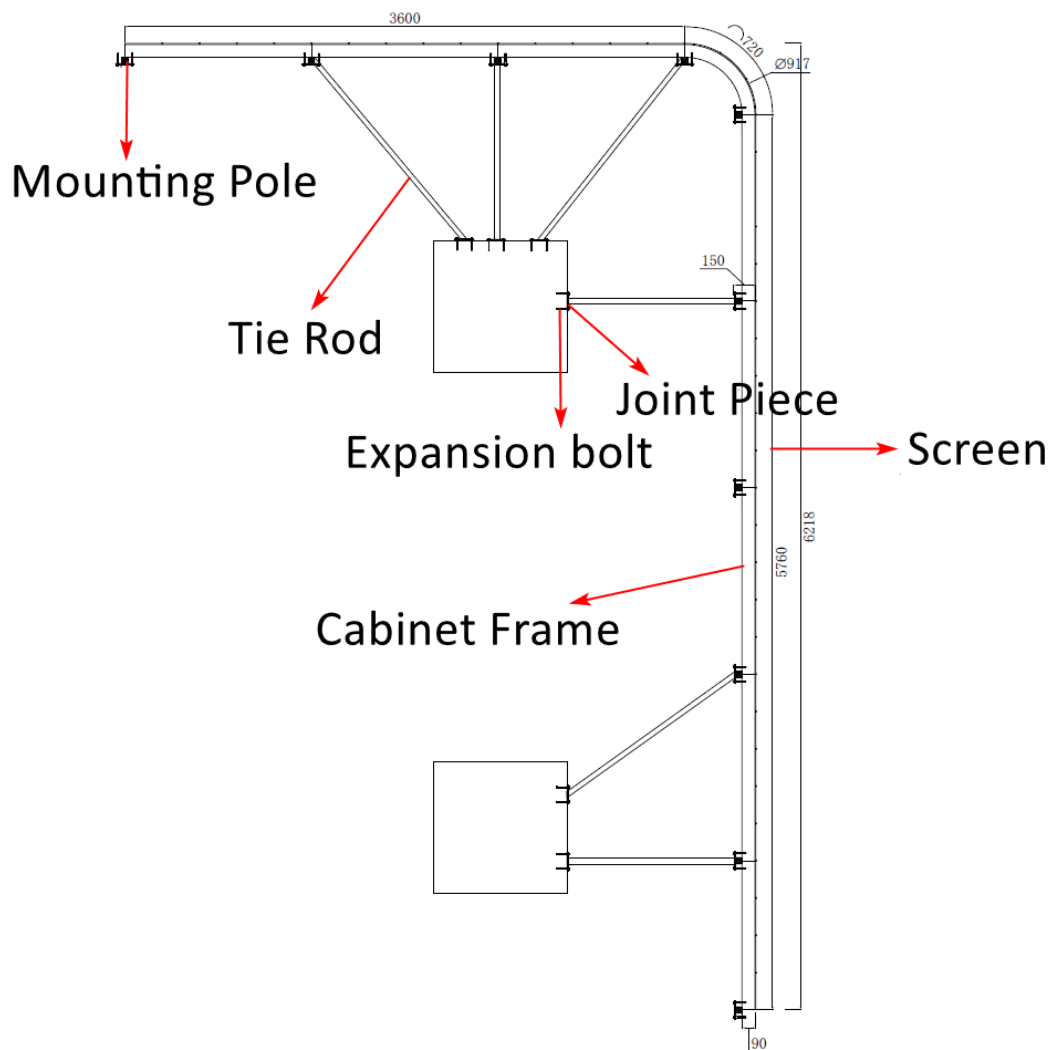

Figure 2-8 Finish the Screen Installation (Top View)

### Note

The standard thickness of the sheet metal cabinet with modules is 85 mm. The partial thickness is no more than 65 mm, containing mounting pole, connector and screws, and the overall thickness is no more than 150 mm. The cylindrical screen project needs to calculate the size of a circle of modules according to the actual dimensions and round up to the final diameter of the LED screen.

## 2.3 Connect Power Cables

The standard load capability of a power supply for indoor LED module is 3 rows and 2 columns. You can refer to the load capability tablet to find the detailed data.

**Note**

- It is recommended to connect 8 power supplies in parallel and connect them to a 220 V power supply.
- The total wattage of all power supplies cannot exceed the wattage of the distributed power source.

Table 2-1 The Load Capability of A Power Supply

Pixel Pitch of the Module	The Load Capability of A Power Supply	Distribution of Modules Loaded by A Power Supply (Row × Column)	Dimension of Module (W × H) (mm)
P1.2	6	3 × 2	320 × 160
P1.5	6	3 × 2	320 × 160
P1.8	6	3 × 2	320 × 160
P2.0	6	3 × 2	320 × 160
P2.5	6	3 × 2	320 × 160

### 2.3.1 P1.2 Module

The maximum load capability of a power supply for P1.2 module is six, and the maximum load capability of a receiving card for P1.2 module is six. Therefore, one power supply is required to connect six P1.2 modules.

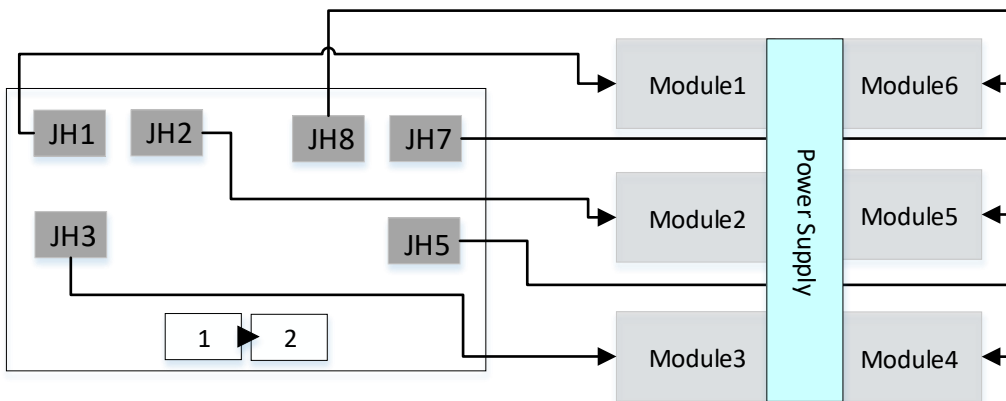

Figure 2-9 Max. Load of A Power Supply for P1.2 Module

### 2.3.2 P1.5 Module

The maximum load capability of a power supply for P1.5 module is six, and the maximum load capability of a receiving card for P1.5 module is twelve. Therefore, two power supplies are required to connect twelve P1.5 modules.

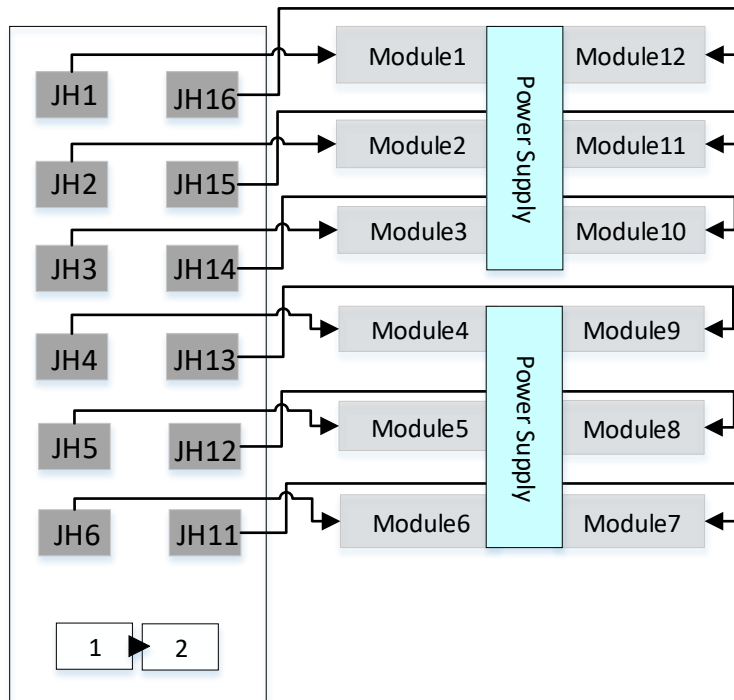

Figure 2-10 Max. Load of A Power Supply for P1.5 Module

**Note**

The maximum load capability of a power supply for P1.8, P2.0, P2.5 modules are same as the maximum load capability of a power supply for P1.5 module.

## 2.4 Connect Signal Cables

Table 2-2 The Load Capability of A Receiving Card

Pixel Pitch of the Module	The Load Capability of A Receiving Card	Distribution of Modules Loaded by One Receiving Card (Row × Column)	Dimension of Module (W × H) (mm)
P1.2	6	3 × 2	320 × 160
P1.5	12	6 × 2	320 × 160
P1.8	12	6 × 2	320 × 160
P2.0	12	6 × 2	320 × 160
P2.5	12	6 × 2	320 × 160

### 2.4.1 P1.2 Module

The standard load capability of a receiving card for P1.2 indoor LED module is 3 rows and 2 columns. You can refer to the load capability table to find the detailed data.

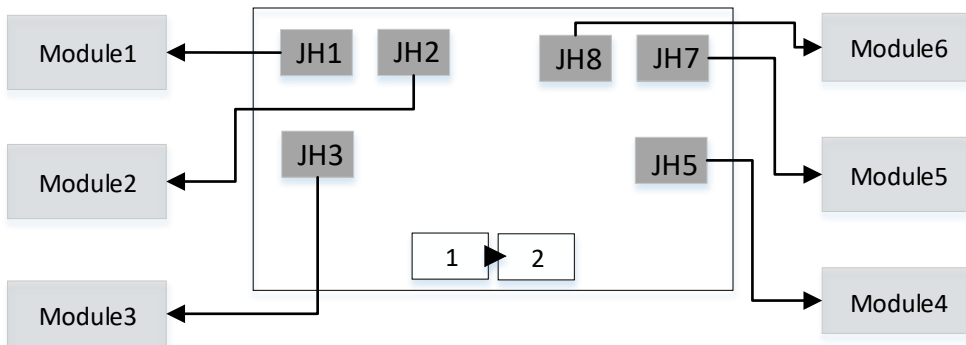

Figure 2-11 Max. Load of A Receiving Card for P1.2 Module

### 2.4.2 P1.5 Module

The standard load capability of a receiving card of P1.5/P1.8/P2.0/P2.5 indoor LED module is 6 rows and 2 columns. You can refer to the load capability table to find the detailed data.

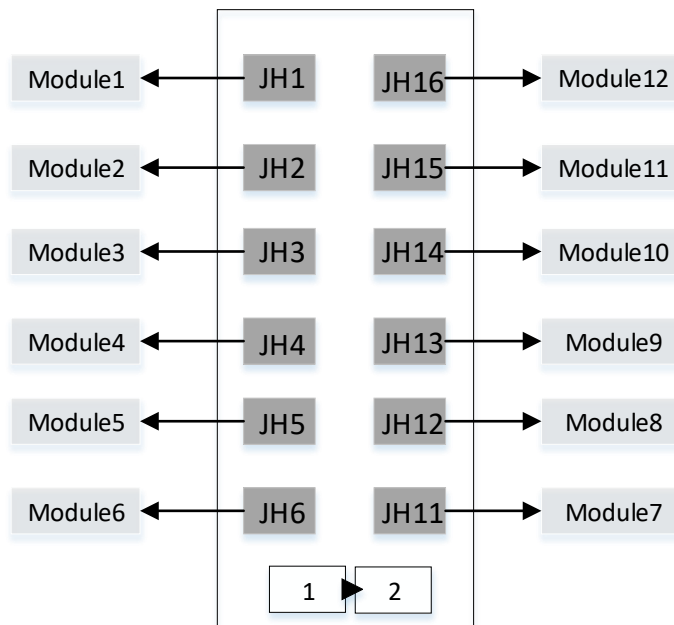

Figure 2-12 Max. Load of A Receiving Card for P1.5 Module

**Note**

- If there are not enough rows and columns for the receiving card, the signal cables will not be in use. That is, if there is only one row of modules, you can use only one receiving card to connect the modules, and the rest interface of the receiving card will not be in use.
- The maximum load capability of a receiving card for P1.8, P2.0, P2.5 modules are same as the maximum load capability of a receiving card for P1.5 module.

## Chapter 3 Configuration

### 3.1 Stitch P1.2 Module LED Display

Take stitching 8 rows and 7 columns of P1.2 module LED display as an example. The configuration information is shown in the table below.

Table 3-1 Configuration Information

Parameters	Specification
Dimension of Module	320 mm × 160 mm
Modules in a Row	7 modules
Modules in a Column	8 modules
Max. Load of a Power Supply in a Row	2 modules
Max. Load of a Power Supply in a Column	3 modules
Number of Power Supply in 8 Rows of Modules	$8/3=2$ , 2 rows of modules are left
Number of Power Supply in 7 Columns of Modules	$7/2=3$ , 1 column of modules are left
Max. Load of A Receiving Card in a Row	2 modules
Max. Load of A Receiving Card in a Column	3 modules
Number of Receiving Card in 8 Rows of Modules	$8/3=2$ , 2 rows of modules are left
Number of Receiving Card in 7 Columns of Modules	$7/2=3$ , 1 column of modules are left

As is shown in the table, twelve power supplies are need to stitch 8 rows and 7 columns of P1.2 module LED display.

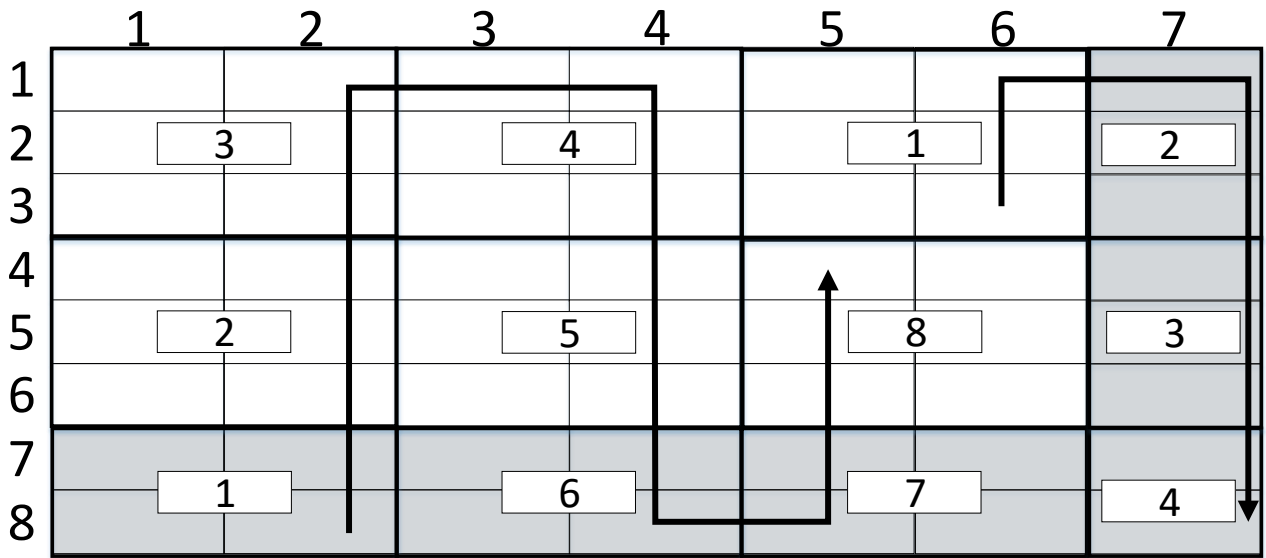

Figure 3-1 Distribution of Modules Load by 12 Power Supplies

Twelve receiving cards are needed to stitch 8 rows and 7 columns of P1.2 module LED display.

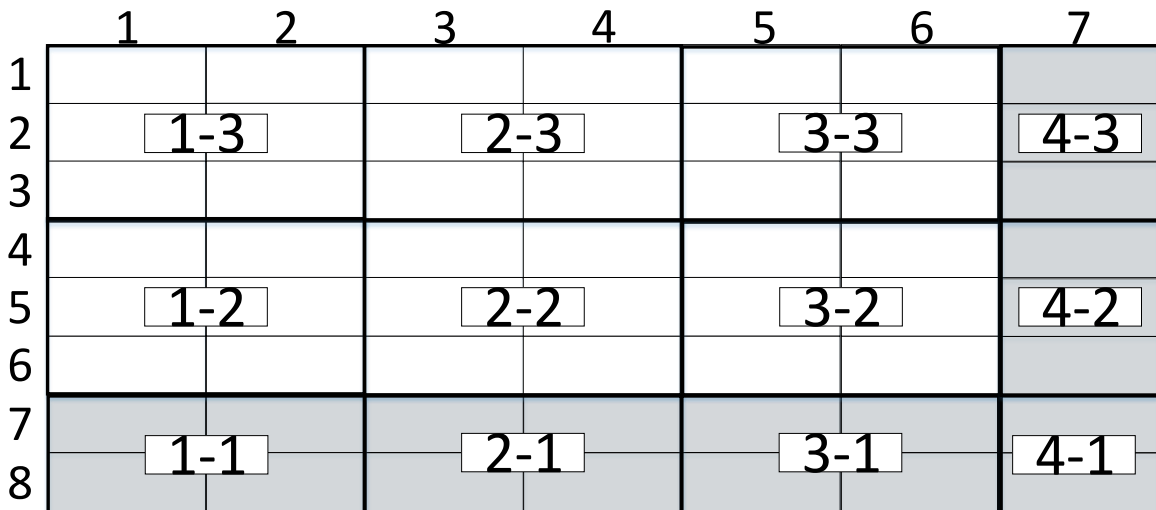

Figure 3-1 Distribution of Modules Loaded by 12 Receiving Cards

The max load of a receiving card for P1.2 modules is 6 modules. The actual signal cables connection is shown as below.

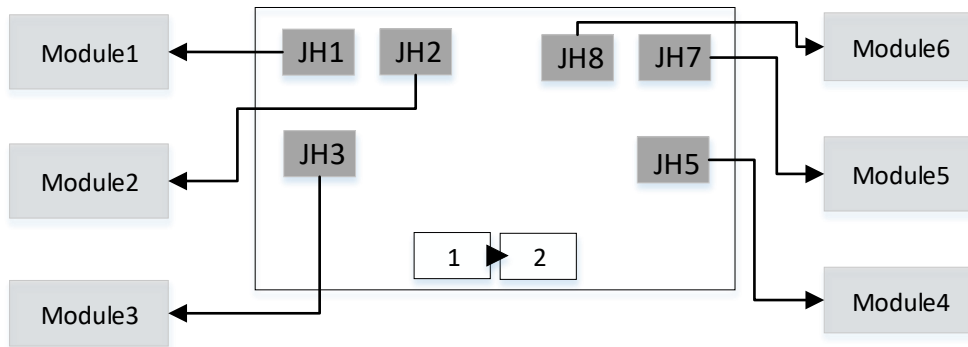

Figure 3-2 Max. Load of A Receiving Card for P1.2 Modules

The max load of a receiving card for P1.2 modules in a column is 3 modules. Therefore, three more receiving cards are needed to connect the modules in the remaining two rows indicated by 1-1, 2-1, 3-1. As is shown in the following figure, interfaces JH1, JH2, JH7, and JH8 in the first row of the receiving card are used to connect remaining modules, and the rest of interfaces of the receiving card are vacant.

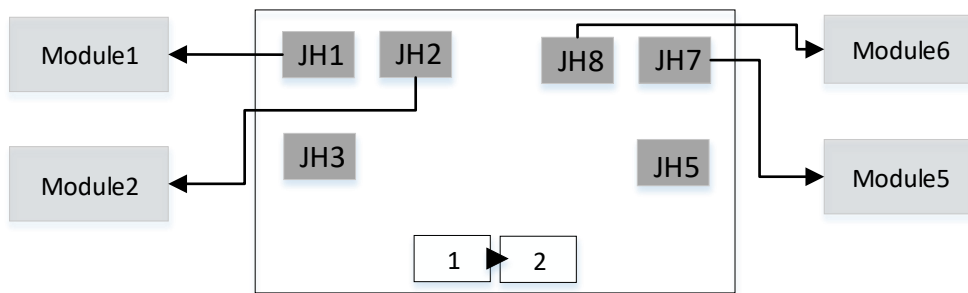

Figure 3-3 Modules Distribution Diagram in 1\_1

The max load of a receiving card for P1.2 modules in a row is 2 modules. Therefore, two more receiving cards are needed to connect the modules in the remaining column indicated by 4-3, 4-2. As is shown in the following figure, interfaces JH1 to JH3 in the left column of the receiving card are used to connect remaining modules, and the rest of interfaces of the receiving card are vacant.

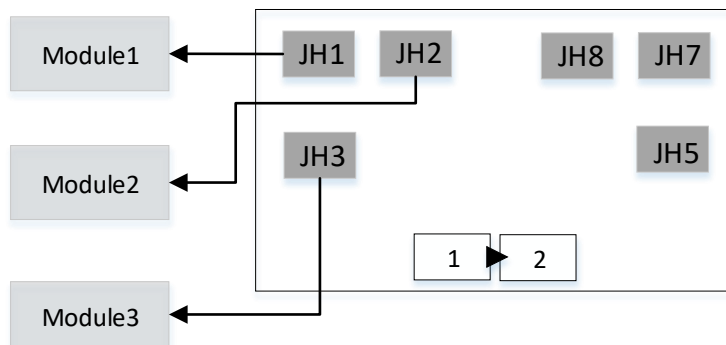

Figure 3-4 Modules Distribution Diagram in 4-3

The remaining modules indicated by 4-1 can be connected to interface JH1 and JH2 in the first row in the left column of one more receiving card and the rest of interfaces are vacant.

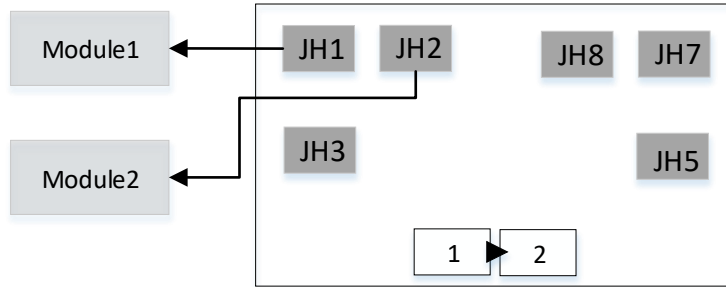

Figure 3-5 Modules Distribution Diagram in 4-1

### 3.2 Stitch P1.5 Module LED Display

Take stitching 13 rows and 7 columns of P1.5 module LED display as an example. The configuration information is shown in the table below.

Table 3-2 Configuration Information

Parameters	Specification
Dimension of Module	320 mm × 160 mm
Modules in a Row	13 modules
Modules in a Column	7 modules
Max. Load of a Power Supply in a Row	2 modules
Max. Load of a Power Supply in a Column	3 modules
Number of Power Supply in 13 Rows of Modules	$13/3=4$ , 1 row of modules are left
Number of Power Supply in 7 Columns of Modules	$7/2=3$ , 1 column of modules are left
Max. Load of A Receiving Card in a Row	2 modules
Max. Load of A Receiving Card in a Column	6 modules
Number of Receiving Card in 13 Rows of Modules	$13/6=2$ , 1 row of modules are left
Number of Receiving Card in 7 Columns of Modules	$7/2=3$ , 1 column of modules are left

As is shown in the table, twenty power supplies are needed to stitch 13 rows and 7 columns of P1.5 module LED display.

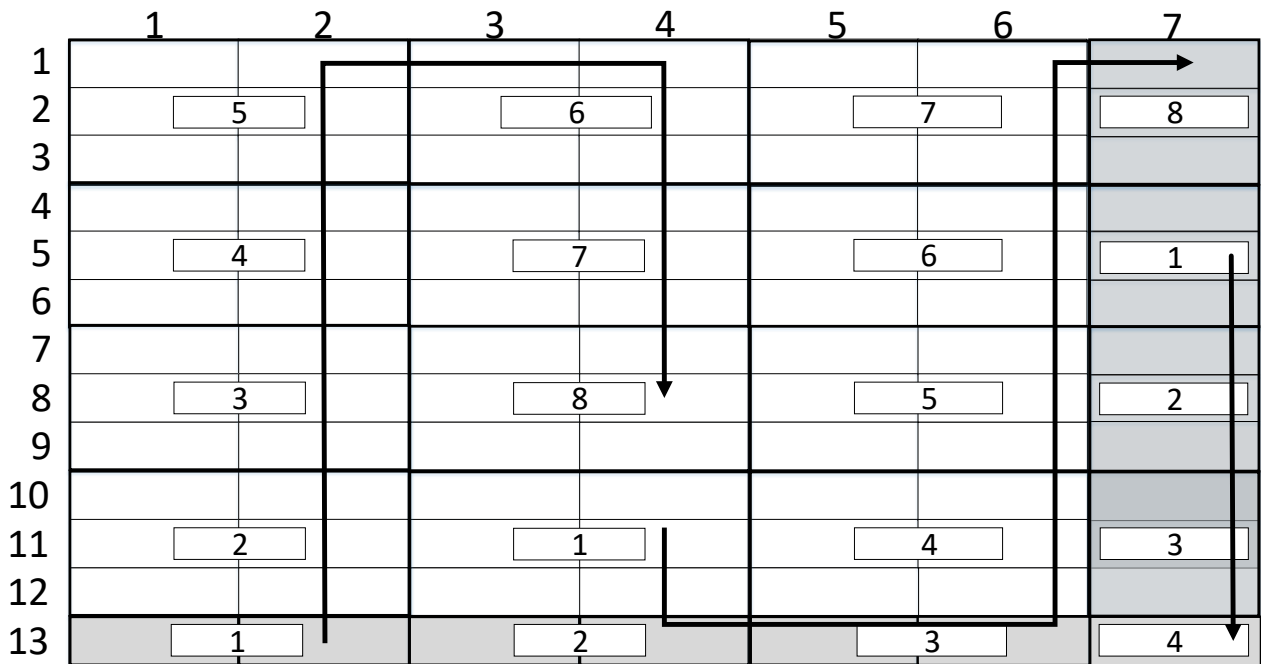

Figure 3-6 Distribution of Modules Loaded by 20 Power Supplies

Twelve receiving cards are needed to stitch 13 rows and 7 columns of P1.5 module LED display.

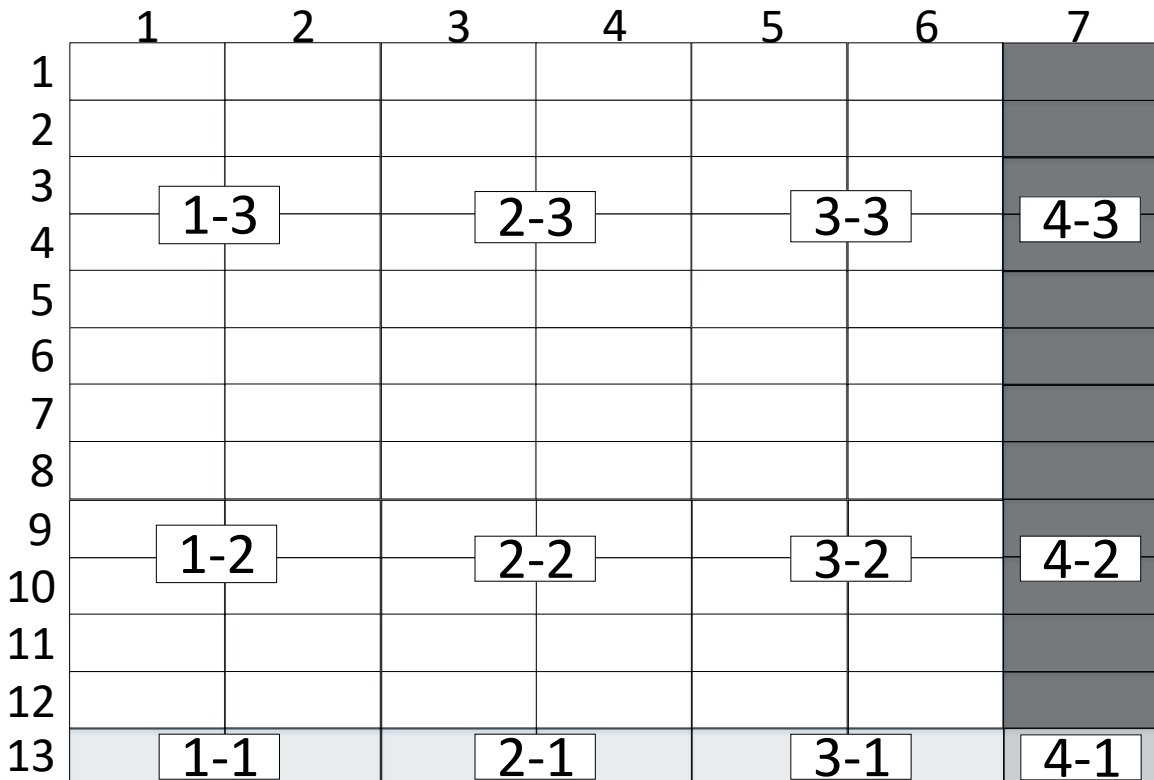

Figure 3-7 Distribution of Modules Loaded by 12 Receiving Cards

The max load of a receiving card for P1.5 modules is 12 modules. The actual signal cables connection is shown as below.

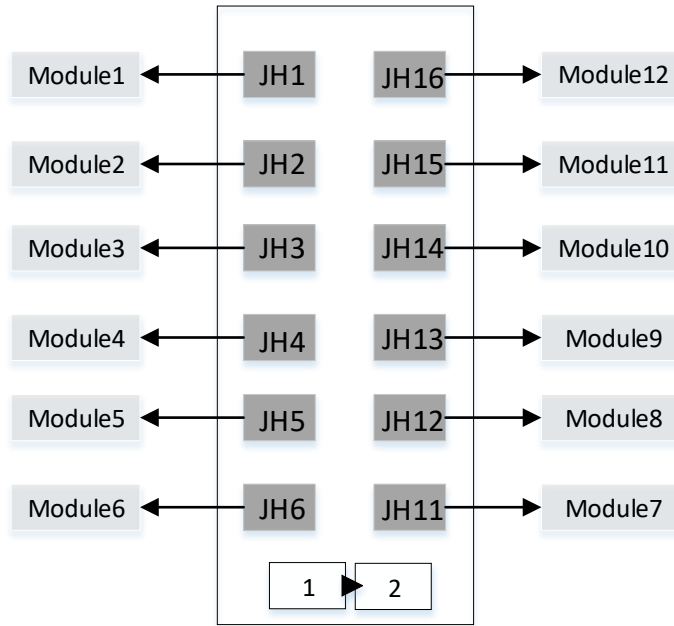

Figure 3-8 Max. Load of A Receiving Card for P1.5 Modules

The max load of a receiving card for P1.5 modules in a column is 6 modules. Therefore, three more receiving cards are needed to connect the modules in the remaining row indicated by 1-1, 2-1, 3-1. As is shown in the following figure, interfaces JH1 and JH16 in the first row of the receiving card are used to connect remaining modules, and the rest of interfaces of the receiving card are vacant.

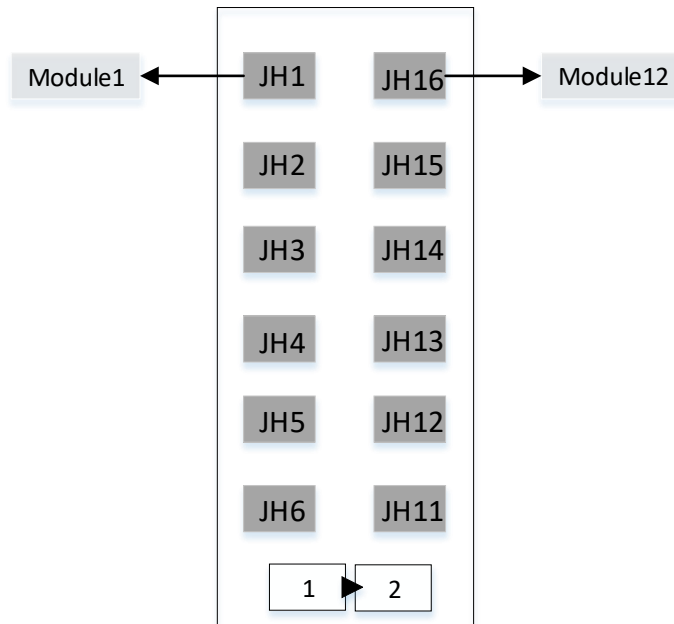

Figure 3-9 Modules Distribution Diagram in 1-1

The max load of a receiving card for P1.5 modules in a row is 2 modules. Therefore, two more receiving cards are needed to connect the modules in the remaining column indicated by 4-3, 4-2. As is shown in the following figure, interfaces JH1 to JH6 in the left column of the receiving card are used to connect remaining modules, and the rest of interfaces of the receiving card are vacant.

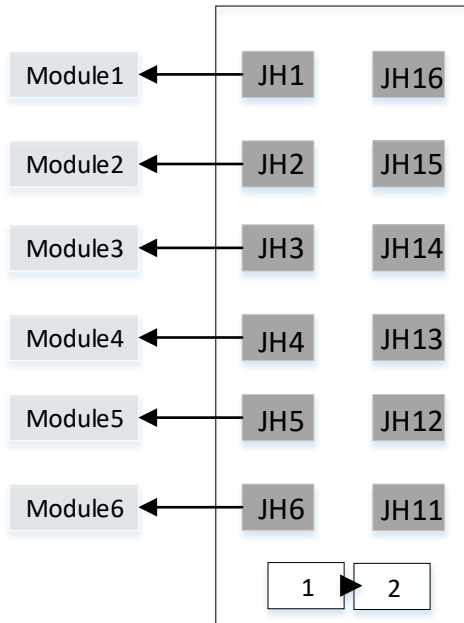

Figure 3-10 Modules Distribution Diagram in 2-2

The remaining modules indicated by 4-1 can be connected to interface JH1 in the first row in the left column of one more receiving card and the rest of interfaces are vacant.

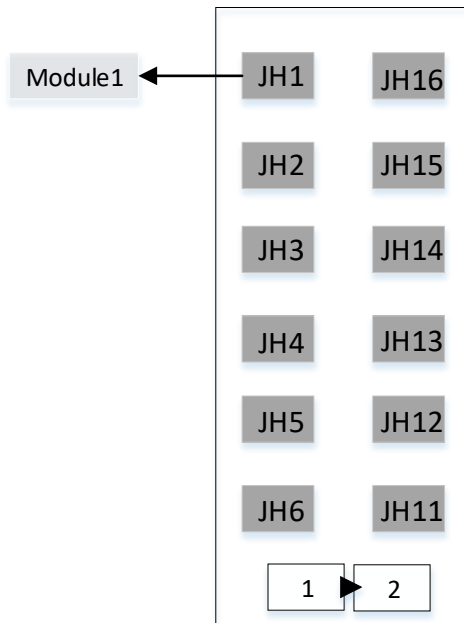

Figure 3-11 Modules Distribution Diagram in 2-1



See Far, Go Further